

**CITY OF FARMINGTON HILLS
BUILDING DIVISION
31555 W. Eleven Mile Road, Farmington Hills, MI 48336
248-871-2450**

DUAL WATER METER REQUIREMENTS (EFFECTIVE JULY 1, 2010)

1. A Farmington Hills Plumbing Permit must be presented to Oakland County when making application for the County Dual Meter Permit. The \$85.00 plumbing permit fee includes the required final inspection by the City of Farmington Hills (see handout explaining the procedure for requesting inspections).
2. Oakland County will issue a water meter after the dual meter permit is obtained. The permit can be obtained in person or by mail (copy of the Farmington Hills plumbing permit must be included with application) at the following location: Oakland County Public Works, #1 Public Works Drive, Waterford, MI (248) 858-1110). The meter can be obtained in person at the following location: Water Maintenance Office, 22430 West 8 Mile Road, Southfield, MI (248-356-6218).
3. Minimum meter size for the outside maintenance use meter (m-2) shall be 1". The cost for this meter is \$310.00 which includes the exterior meter readout installation charge.
4. The Oakland County dual meter permit charge is \$50.00
5. The existing water meter shall be re-installed as M-1 by the permit holder.
6. Both meters shall be fully independent – requiring a full opening gate or ball valve before and after each meter (see diagram).
7. Both meters shall have an electrical jumper cable (#4 minimum) installed for ground continuity. (See diagram).
8. Owner/Plumber to assure that the outside readout cable can be accommodated for both meters. This may require the Owner/Plumber to install a conduit through the building wall.
9. New homes may make application and pay for their DMS meter along with their normal water permit charges at WRC at the location indicated in #2 above. After the permit is issued, the permit holder may obtain their meters at the location indicated in #2 above. A copy of the City plumbing permit is not required for new homes.
10. It is the permit holder's responsibility to install the water meter(s) and contact the WRC Water Maintenance Unit to have the meter installation inspected and the remote reader installed. Access to building must be provided for final inspection.

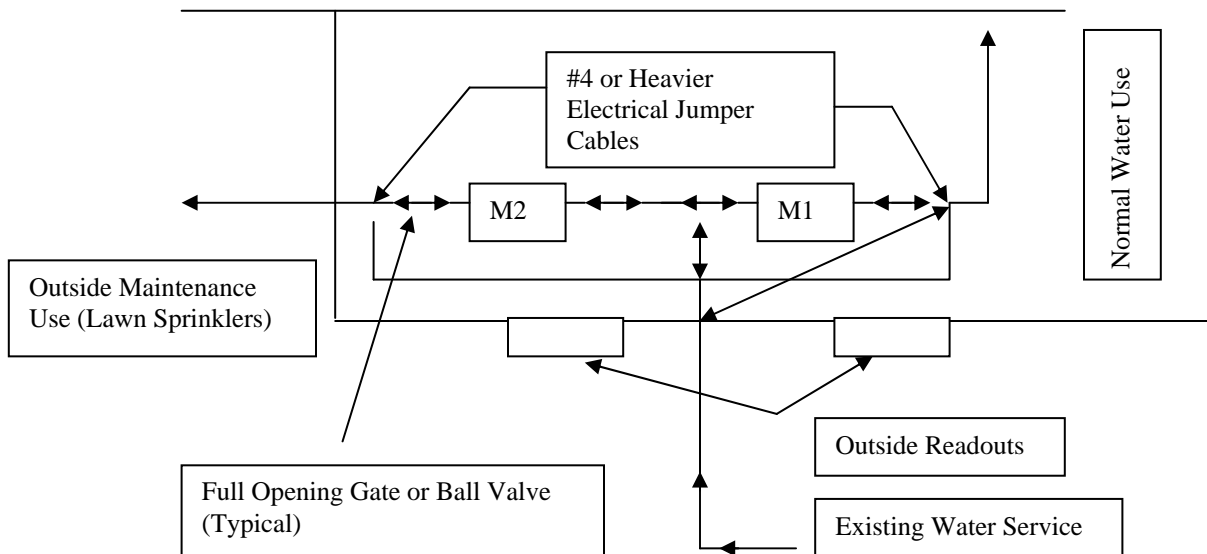



TO MATERIALS MANAGEMENT

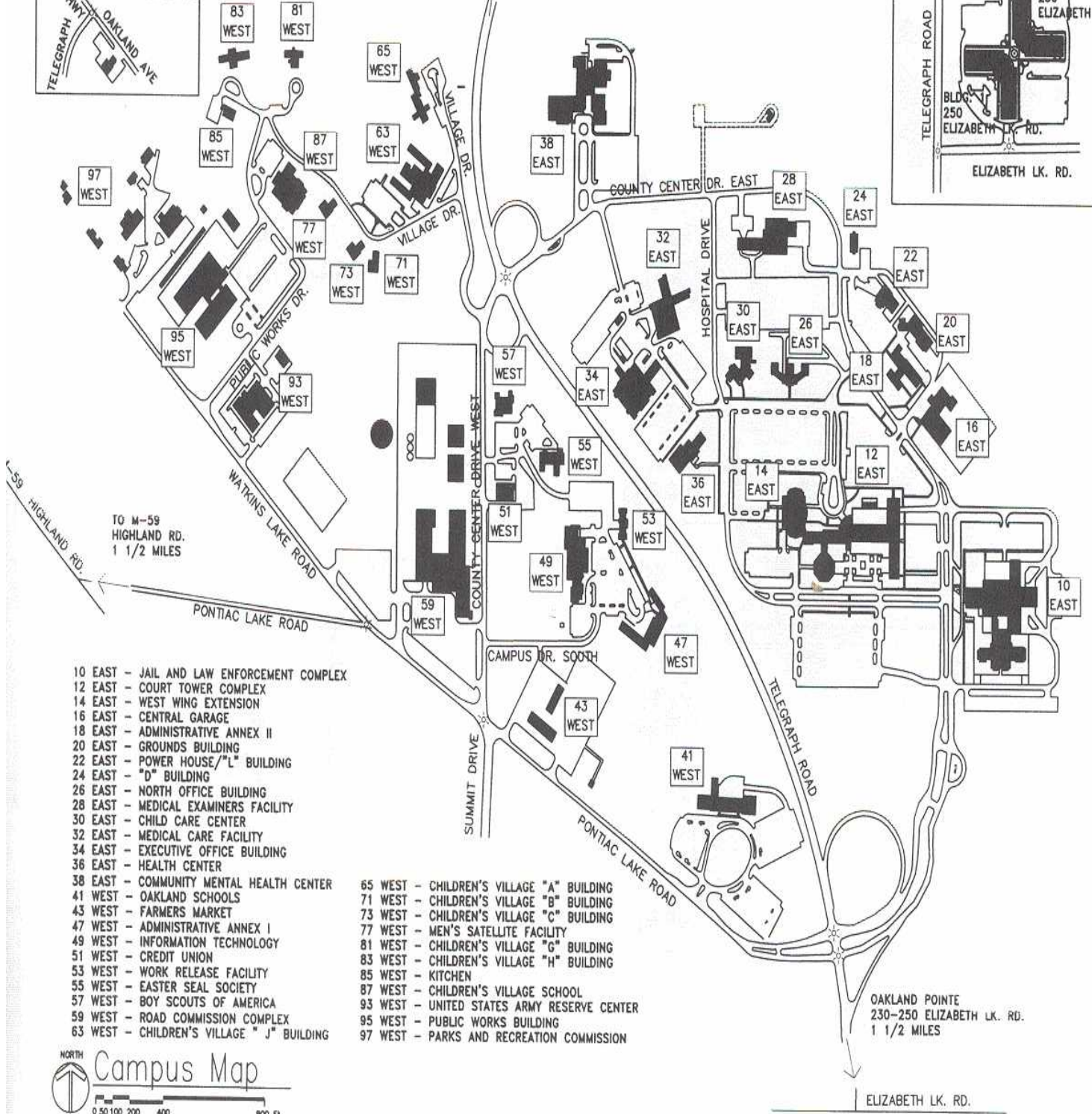
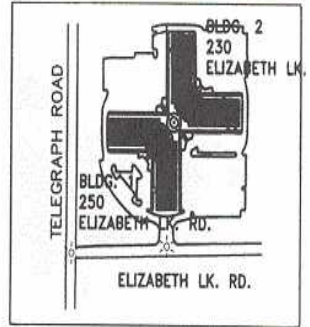

- 10 EAST - JAIL AND LAW ENFORCEMENT COMPLEX
- 12 EAST - COURT TOWER COMPLEX
- 14 EAST - WEST WING EXTENSION
- 16 EAST - CENTRAL GARAGE
- 18 EAST - ADMINISTRATIVE ANNEX II
- 20 EAST - GROUNDS BUILDING
- 22 EAST - POWER HOUSE/"L" BUILDING
- 24 EAST - "D" BUILDING
- 26 EAST - NORTH OFFICE BUILDING
- 28 EAST - MEDICAL EXAMINERS FACILITY
- 30 EAST - CHILD CARE CENTER
- 32 EAST - MEDICAL CARE FACILITY
- 34 EAST - EXECUTIVE OFFICE BUILDING
- 36 EAST - HEALTH CENTER
- 38 EAST - COMMUNITY MENTAL HEALTH CENTER
- 41 WEST - OAKLAND SCHOOLS
- 43 WEST - FARMERS MARKET
- 47 WEST - ADMINISTRATIVE ANNEX I
- 49 WEST - INFORMATION TECHNOLOGY
- 51 WEST - CREDIT UNION
- 53 WEST - WORK RELEASE FACILITY
- 55 WEST - EASTER SEAL SOCIETY
- 57 WEST - BOY SCOUTS OF AMERICA
- 59 WEST - ROAD COMMISSION COMPLEX
- 63 WEST - CHILDREN'S VILLAGE "J" BUILDING

- 65 WEST - CHILDREN'S VILLAGE "A" BUILDING
- 71 WEST - CHILDREN'S VILLAGE "B" BUILDING
- 73 WEST - CHILDREN'S VILLAGE "C" BUILDING
- 77 WEST - MEN'S SATELLITE FACILITY
- 81 WEST - CHILDREN'S VILLAGE "G" BUILDING
- 83 WEST - CHILDREN'S VILLAGE "H" BUILDING
- 85 WEST - KITCHEN
- 87 WEST - CHILDREN'S VILLAGE SCHOOL
- 93 WEST - UNITED STATES ARMY RESERVE CENTER
- 95 WEST - PUBLIC WORKS BUILDING
- 97 WEST - PARKS AND RECREATION COMMISSION

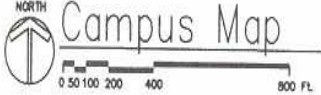

OAKLAND POINTE
230-250 ELIZABETH LK. RD.
1 1/2 MILES

ELIZABETH LK. RD.